



YOUR
TALENT
YOUR
FUTURE
YOUR
FIRST BAR

start up*

start up*

IL TUO TALENTO, IL TUO FUTURO,
IL TUO PRIMO BAR



IL BAR, ACCESSIBILE E CREATIVO

START UP È UN NUOVO MODO DI INTENDERE IL SERVIZIO BAR. UN'UNITÀ ESSENZIALE, CHE INTEGRA TUTTI GLI ELEMENTI INDISPENSABILI AL FUNZIONAMENTO DI UN LOCALE. FRONTE E RETRO COMPONGONO UN SERVIZIO BAR BASILARE CHE RENDE ACCESSIBILE A CHIUNQUE LA POSSIBILITÀ DI APRIRE IL SUO LOCALE.

**YOUR TALENT, YOUR FUTURE, YOUR FIRST BAR
THE BAR, ACCESSIBLE AND CREATIVE**

start up is a new concept in bar service. An essential unit, combining all the vital elements for operating a bar. Front and back make up an essential bar service, making it possible for anyone to open a bar.

**VOTRE TALENT, VOTRE AVENIR, VOTRE PREMIER BAR
LE BAR ACCESSIBLE ET CRÉATIF**

start up est une nouvelle manière de concevoir le service de bar, lequel devient une unité fondamentale qui intègre tous les éléments indispensables au fonctionnement d'un établissement. L'arrière et la façade composent un service de bar essentiel, à la portée de tous ceux qui souhaitent ouvrir leur propre établissement.

**DEIN TALENT, DEINE ZUKUNFT, DEINE ERSTE BAR
DIE BAR – MACHBAR UND KREATIV**

start up interpretiert den Barservice auf eine ganz neue Art. Eine essentielle Einheit, in der alle unverzichtbaren Elemente für den Betrieb eines Lokals integriert sind. Vorder- und Rückseite bilden den grundlegenden Barservice, der jedermann die Möglichkeit bietet, ein eigenes Lokal zu eröffnen.

**TU TALENTO, TU FUTURO, TU PRIMER BAR
EL BAR, ACCESSIBLE Y CREATIVO**

start up es una nueva manera de concebir el servicio de bar. Una unidad esencial que integra todos los elementos indispensables para el funcionamiento de un local. La parte anterior y la posterior forman un servicio de bar básico que pone al alcance de todos la posibilidad de abrir el propio local.



DOVE C'È VOGLIA DI FUTURO

WHERE THERE IS A DESIRE FOR THE FUTURE / IMAGINONS L'AVENIR
DAS STREBEN NACH ZUKUNFT / DONDE HAY GANAS DE FUTURO

ESPERIENZA E INNOVAZIONE CON RADICI ITALIANE

START UP NASCE DA IFI, DAL SAPER FARE ITALIANO
E DALLA DEDIZIONE PER LA RICERCA E LA CULTURA DEL PROGETTO.



EXPERIENCE AND INNOVATION
WITH ITALIAN ROOTS.
start up has been created by IFI,
from Italian know-how and
dedication to research and
the design culture.

UNE COMPÉTENCE ET UNE
CAPACITÉ À INNOVER QUI PUISENT
LEURS RACINES EN ITALIE.
start up est le fruit du savoir-faire
italien d'IFI et de sa passion pour
la recherche et la culture du projet.

ERFAHRUNG UND INNOVATION
MIT ITALIENISCHEN WURZELN.
start up kommt von IFI, d.h.
vom italienischen Können
und der engagierten Suche
nach der Projektkultur.

EXPERIENCIA E INNOVACIÓN
CON RAÍCES ITALIANAS.
start up nace de IFI, del saber
hacer italiano y de la dedicación
por la investigación y la cultura
del proyecto.





UN PROGETTO SOCIALE

START UP METTE AL CENTRO DEI NUOVI LOCALI PUBBLICI LE RELAZIONI TRA LE PERSONE. VALORIZZA IL TALENTO E LE RETI PERSONALI. UN PROGETTO PER TUTTI, CHE PERMETTE DI INIZIARE A COSTRUIRE I PROPRI SOGNI.



START UP BASIC L.3000 SX H951 VT
(3.020 mm / 118.90")



A SOCIAL PROJECT
start up puts interpersonal relations at the heart of new public bars. It promotes talent and personal networks. A project for everyone, which allows everyone to start to make their dreams reality.

UN PROJET SOCIAL
avec start up, les relations interpersonnelles occupent une position centrale dans les nouveaux établissements publics. start up met en valeur le talent et les réseaux personnels. Un projet pour tous ceux qui souhaitent commencer à réaliser leurs rêves.

EIN SOZIALES PROJEKT
start up stellt die zwischenmenschlichen Beziehungen in den Mittelpunkt des neuen Lokals. Das Talent und das persönliche Beziehungsgeflecht werden zur Geltung gebracht. Ein Projekt für alle, denn jedermann erhält die Chance, den eigenen Traum zu verwirklichen.

UN PROYECTO SOCIAL
start up sitúa en el centro de los nuevos locales públicos las relaciones entre las personas. Valoriza el talento y las redes personales. Un proyecto para todos que nos permite empezar a materializar nuestros propios sueños.



UN NUOVO SOCIAL NETWORK

A NEW SOCIAL NETWORK / UN NOUVEAU RÉSEAU SOCIAL
EIN NEUES SOCIAL NETWORK / UN NUEVO SOCIAL NETWORK

BICYCLING
AGAINST
OIL WARS

CAPACITÀ DI IMMAGINARE

PER COMINCIARE A SOGNARE PUÒ BASTARE QUELLA VECCHIA OFFICINA
ABBANDONATA, DOVE IL NONNO RIPARAVA LE BICICLETTE.

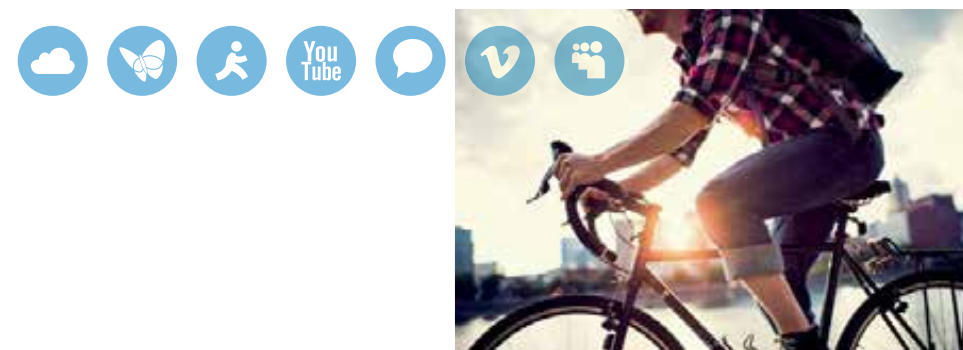

IMAGINATION
Dreams can start from that
old abandoned workshop,
where your grandfather used
to repair bikes.

CAPACITÉ D'IMAGINATION
Pour commencer à rêver, il suffit
d'un vieux garage abandonné,
comme celui où votre grand-père
réparait les vélos.

VORSTELLUNGSKRAFT
Um zu träumen zu beginnen, genügt
die alte verlassene Werkstatt,
wo der Großvater einst Fahrräder
reparierte.

CAPACIDAD DE IMAGINAR
Para empezar a soñar puede
ser suficiente ese viejo taller
abandonado, donde el abuelo
reparaba las bicicletas.

TOCCHI DI PERSONALITÀ

PROPOSTO IN UNA CONFIGURAZIONE BIANCO-NERO
PULITA E LINEARE, IL SERVIZIO PUÒ ESSERE
PERSONALIZZATO CON DIVERSI ACCESSORI.

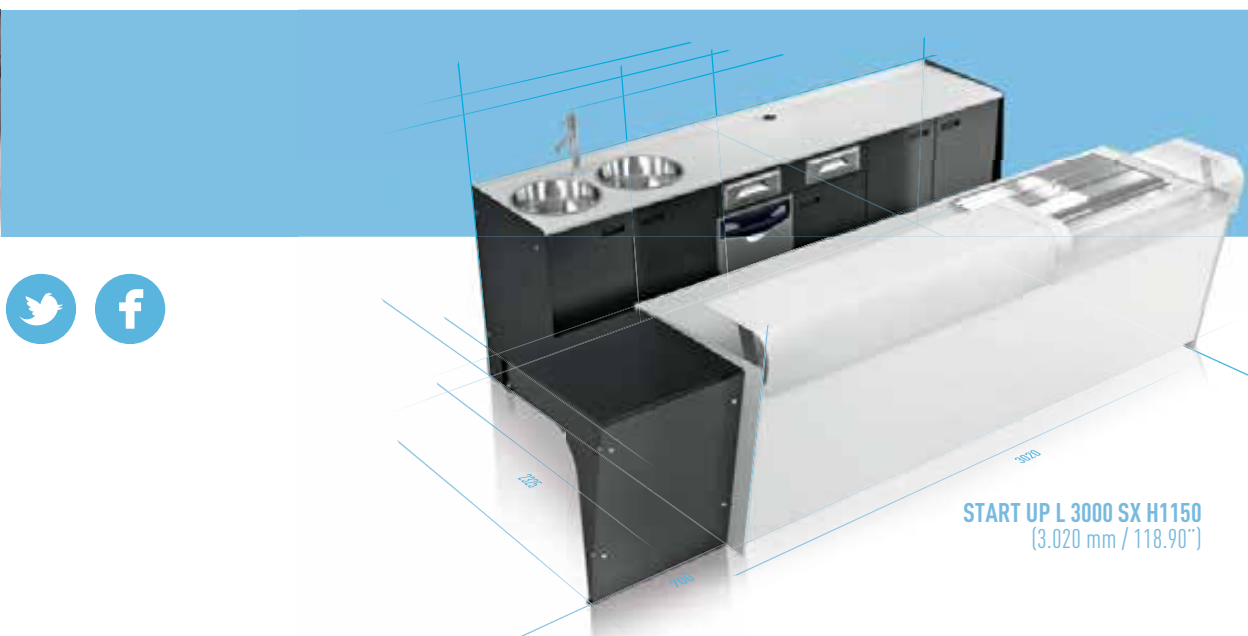

ACCESSORI: ILLUMINAZIONE A LED; PENISOLA; SECONDO LAVELLO;
SECONDO CASSETTO BATTI FILTRO; ANTA PER CHIUSURA PARZIALE VANO LAVA TAZZE.

ACCESSORIES: LED lighting; peninsula unit; second sink; second drawer for coffee grounds; door long partly closing glass washer compartment.
ACCESSOIRES: éclairage à LED; meublecaisse; deuxième évier; deuxième tiroir à marc; porte pour fermeture partielle du lave tasses.
ZUBEHÖRTEILE: LED-Beleuchtung, Halbinsel, zweites Spülbecken, zweite Kaffeesatz-Lade, Tür zum teilweisen schliessen des tassenspülraums.
ACCESORIOS: iluminación con LED; península; segundo fregadero; segundo cajón residuos café; puerta para cierre parcial compartimento lavatazas.



PERSONAL TOUCHES
The service is offered in a clean, linear black-and-white configuration and can be customised with various accessories.

UNE TOUCHE DE PERSONNALITÉ
Proposé dans une configuration blanche et noire, épurée et linéaire, le service peut se personnaliser au moyen de différents accessoires.

DIE PERSÖNLICHE NOTE
Der in einer sauberen und linearen Schwarz-Weiß-Konfiguration gebotene Service kann mit verschiedenem Zubehör individuell gestaltet werden.

TOQUES DE PERSONALIDAD
Propuesto en una configuración blanco-negro limpia y lineal, el servicio puede personalizarse con distintos accesorios.

START UP L 3000 SX H1150
(3.020 mm / 118.90")



start up*

IL TUO SEGNO

IL PROGETTO START UP È PENSATO PER ESALTARE LA CREATIVITÀ.
RENDERE ORIGINALE START UP È FACILISSIMO.
BASTA CREARE UNA DECORAZIONE GRAFICA DI QUALSIASI TIPO,
OPPURE INVIARE UN FILE GRAFICO DIRETTAMENTE A IFI.
O, PERCHÉ NO, ARMARSI DI VERNICE SPRAY!

*

YOUR OWN MARK
Start up has been devised to highlight creativity in design and graphics. Making start up original couldn't be easier. Just create a graphic decoration of any type, or send a graphics file straight to IFI. Or, why not, get hold of some spray paint!

VOTRE SIGNE DISTINCTIF
Le projet start up est conçu pour exalter la créativité conceptuelle et la présentation. Il est très facile de rendre start up original. Il suffit de créer un décor graphique, d'en envoyer le fichier directement à IFI pour que celui-ci devienne le décor de votre futur bar ou encore, pourquoi pas, de s'armer d'une bombe de peinture !

DEIN PERSÖNLICHES ZEICHEN
Das start up-Projekt ist dafür ausgelegt, die planerische und graphische Kreativität zur Geltung zu bringen. Es ist ganz einfach, start up originell zu gestalten. Mann kann eine beliebige graphische Dekoration gestalten oder einfach eine Graphikdatei an IFI senden. Oder – warum auch nicht – Sprayfarbe verwenden!

DEJA TU HUELLA
El proyecto start up está pensado para exaltar la creatividad proyectual y gráfica. Hacer original start up es facilísimo. Basta crear una decoración gráfica de cualquier tipo, o bien enviar un archivo gráfico directamente a IFI. O, por qué no, ¡armarse de pintura en spray!



ESSENZIALE E **VERSATILE**

ESSENTIAL AND VERSATILE / ESSENTIEL ET POLYVALENT
ESSENTIELL UND VIELSEITIG / ESENCIAL Y VERSÁTIL



ACCESSORI: ILLUMINAZIONE A LED; SECONDO LAVELLO;
SECONDO CASSETTO BATTIFILTRO; SERVIZIO GELATO/GRANITA PANORAMA;
MENSOLA RETRO PER SOLUZIONE A ISOLA.

ACCESSORIES:
LED lighting; second sink; second drawer
for coffee grounds; Panorama gelato/granita
service; back shelf for island solution.

ACCESSOIRES:
éclairage à LED; deuxième évier; deuxième
 tiroir à marc; service gelato/granité Panorama;
étagère arrière pour solution en îlot.

ZUBEHÖRTEILE:
LED-Beleuchtung, zweites Spülbecken, zweite
Kaffeersatz-Lade, Gelato-/Granita-Service
Panorama, Rückenablage für Inselösung.

ACCESORIOS:
iluminación con LED; segundo fregadero;
segundo cajón residuos café; servicio gelato/
granizado Panorama; balda posterior para la
solución isla.





SALUTE E IGIENE COME VALORI

START UP TUTELA LA SALUTE DEGLI OPERATORI. IL PIANO IN POSTFORMING, FACILISSIMO DA PULIRE E CON EMISSIONI DI FORMALDEIDE NOTEVOLMENTE INFERIORI AI LIMITI CONSENTITI, È UNO DEI MOTIVI PER CUI START UP HA OTTENUTO LA "SPECIAL MENTION" AL PREMIO GRANDESIGNETICO INTERNATIONAL AWARD E IL 1° PREMIO INNOVAZIONE HORECA 24 PER LA CATEGORIA ARREDI E MATERIALI.



HEALTH AND SAFETY
start up protects operators' health. The postforming top, which is very easy to clean and with formaldehyde emissions significantly below permitted limits, is one reason why start up obtained a "Special Mention" at the Grandesignetico International Awards and 1st Prize for Innovation at Horeca 24 in the Furnishings and Equipment category.

SANTÉ ET HYGIÈNE
start up protège la santé des opérateurs. Le plan postformé (très facile à nettoyer et avec des émissions de formaldéhyde sensiblement inférieures aux limites admises) est l'une des raisons pour lesquelles start up a obtenu la « Special Mention » au prix Grandesignetico International Award ainsi que le 1er prix d'innovation Horeca 24 pour la catégorie Agencements et Matériaux.

GESUNDHEIT UND HYGIENE
start up schützt die Gesundheit des Personals. Die reinigungsfreundliche Postforming-Fläche mit erheblich unter den zulässigen Grenzwerten liegenden Formaldehyd-Emissionen ist einer der Gründe, aus denen start up die „Special Mention“ bei der Ausschreibung Grandesignetico International Award und den 1. Preis für Innovation Horeca 24 in der Kategorie Einrichtung und Material erhalten hat.

SALUD E IGIENE
start up protege la salud de los operadores. La superficie en postformado, fácil de limpiar y con emisiones de formaldehído muy inferiores a los límites permitidos, es uno de los motivos por los que start up ha obtenido la "Mención Especial" al premio Grandesignetico International Award y el 1° Premio a la Innovación Horeca 24 en la categoría Mobiliario y Materiales.



QUESTIONE DI CLASSE

A MATTER OF CLASS / QUESTION DE CLASSE
EINE FRAGE DER KLASSE / CUESTIÓN DE CLASE



BLACK AND WHITE, THE COLOURS OF EVENING WEAR
 Perfectly at ease in an elegant room, where even the accessories play a fundamental part. How many others would be able to move from more of a grunge look to evening wear, while keeping their charm intact?

BLANC ET NOIR, LES COULEURS DU SMOKING
 Tout à fait à son aise dans un espace élégant où même les compléments jouent un rôle fondamental. Combien sont capables de passer du look grunge au smoking sans rien perdre de leur charme ?

SCHWARZ UND WEISS – DIE FARBEN DES SMOKINGS
 In eleganter Umgebung, wo auch das Zubehör eine grundlegende Rolle spielt, ist diese Gestaltung in ihrem Element. Wer kann es sich schon leisten, vom Grunge-Style zum Smoking zu wechseln, ohne an Faszination einzubüßen?

BLANCO Y NEGRO, LOS COLORES DEL SMOKING
 Perfectamente a sus anchas en un ambiente elegante, donde los complementos también revisten un papel fundamental. ¿Cuántos pueden pasar del look más grunge al smoking manteniendo intacto su encanto?

BIANCO E NERO, I COLORI DELLO SMOKING

PERFETTAMENTE A SUO AGIO IN UN AMBIENTE ELEGANTE,
 DOVE ANCHE I COMPLEMENTI GIOCANO UN RUOLO FONDAMENTALE.
 IN QUANTI POSSONO PASSARE DAL LOOK PIÙ GRUNGE ALLO SMOKING
 MANTENENDO INTATTO IL PROPRIO FASCINO?





ACCESSORI:
ILLUMINAZIONE A LED; SECONDO CASSETTO BATTIFILTRO; SECONDO LAVELLO.

ACCESSORIES: LED lighting; second drawer for coffee grounds; second sink. / ACCESSOIRES: éclairage à LED; deuxième tiroir à marc; deuxième évier. / ZUBEHÖRTEILE: LED-Beleuchtung, zweite Kaffeesatz-Lade, zweites Spülbecken. ACCESORIOS: iluminación con LED; segundo cajón residuos café; segundo fregadero.



START UP L 4000 DX H951 VT
(4.020 mm / 158.27")



ALTRI ACCESSORI

OTHER ACCESSORIES / AUTRES ACCESSOIRES
ANDERES ZUBEHÖR / OTROS ACCESORIOS



CAPPA ASPIRANTE E FILTRANTE E MENSOLE IN LAMIERA VERNICIATA NERA A POLVERI EPOSSIDICHE
Plate extractor hood and shelves painted with black epoxy powder
Hotte aspirante et filtrante et tablettes en tôle peinte avec peintures en poudre époxy de couleur noire
Abzugshaube und filter aus Blech und Ablage, die mit schwarzem Epoxidpulver lackiert wurde
Campana extractora y filtrante y estantes de chapa barnizada con polvo epoxico de color negro



MENSOLA DI CONSUMAZIONE P 220 MM IN LAMIERA VERNICIATA NERA A POLVERI EPOSSIDICHE
Plate shelf 220 mm deep painted with black epoxy powder
Tablette de consommation prof. 220 mm en tôle peinte avec peinture époxy de couleur noire
Ablage Tf. 220 mm aus Blech, das mit schwarzem Epoxidpulver lackiert wurde
Barra de consumo de chapa barnizada con polvo P 220 mm



MENSOLE IN VETRO LINEARI E CURVE
Linear and curved glass shelves
Tablettes en verre linéaires et incurvées
Gerade oder gebogene Glasablagen
Estantes de vidrio rectas y curvas



SERRATURA PER SPORTELLI O CASSETTI REFRIGERATI
Lock for refrigerated doors and drawers
Serrure pour porte ou tiroir réfrigérés
Schloss für Türen oder gekühlt Schubladen
Cerradura para puerta o cajones refrigerados

SEZIONI

SECTION VIEWS / SECTIONS
QUERSCHNITTE / SECCIONES

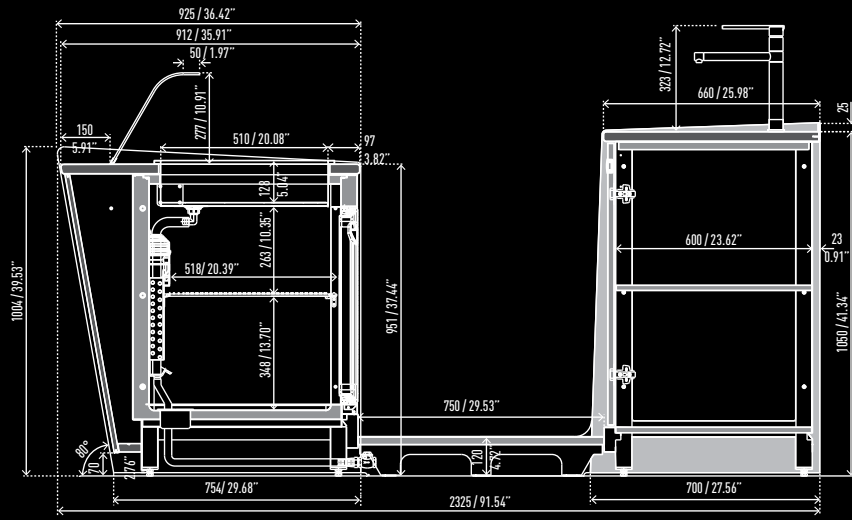

START UP H 951 VT
con vetro di protezione - with safety glass - avec vitre de protection - mit Schutzglas - con vidrio de protección

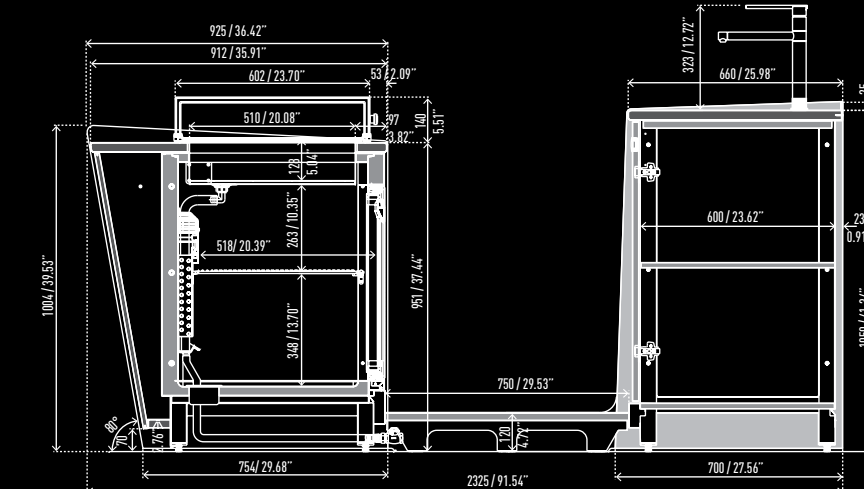

START UP H 951 PL
con copertura in plexiglas - with Plexiglas cover - avec couvercle en plexiglas - mit Plexiglasabdeckung - con cubierta de plexiglas

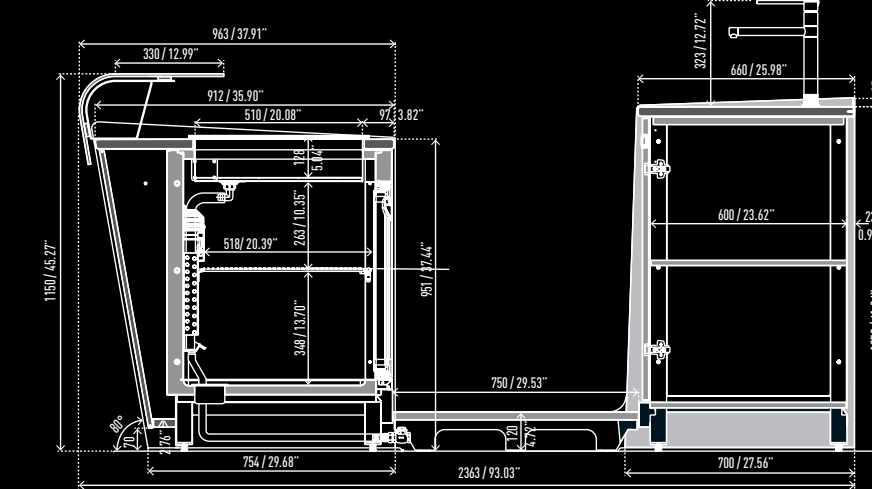

START UP H 951 BC / H 1150
con bancalino in vetro - with glass countertop - avec plan de comptoir en verre - mit Ablagefläche aus Glas - con encimera de vidrio

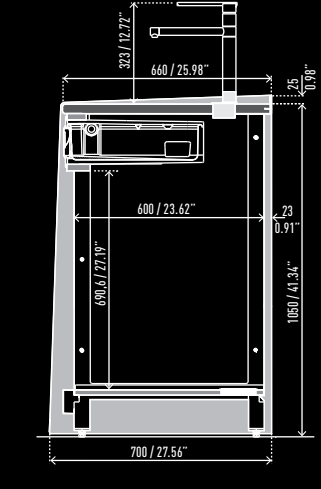

VANO LAVELLO
Sink - Evier - Spülbecken - Fregadero

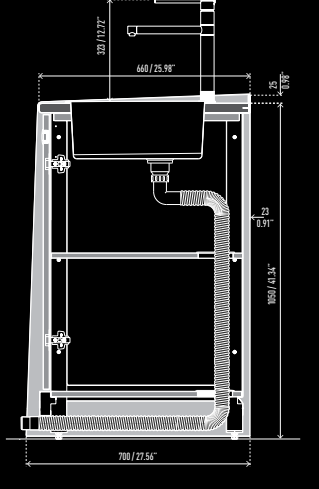

VANO LAVA TAZZE
Glass washer - Lave Tasses - Tassenspüler - Lavatazas

LA GAMMA

THE RANGE / LA GAMME
DIE KOLLEKTION / LA GAMA

L 2000

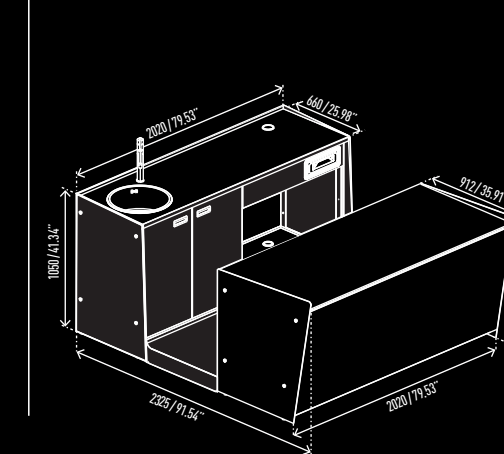

L 2500 SX

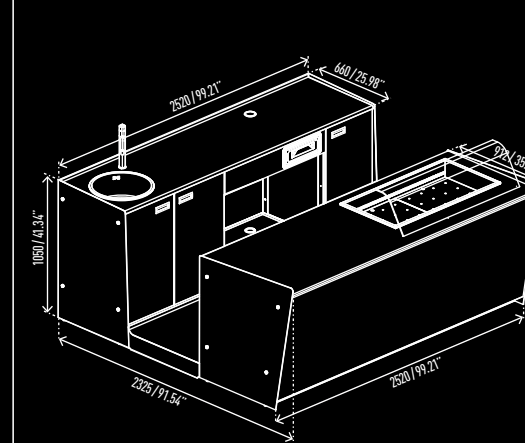

L 2500

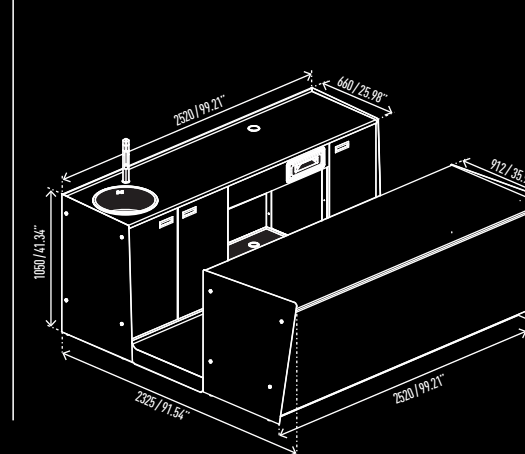

L 3000 SX

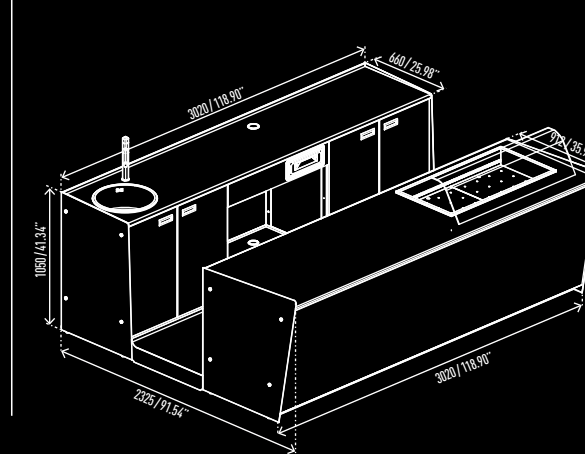

L 3500 DX

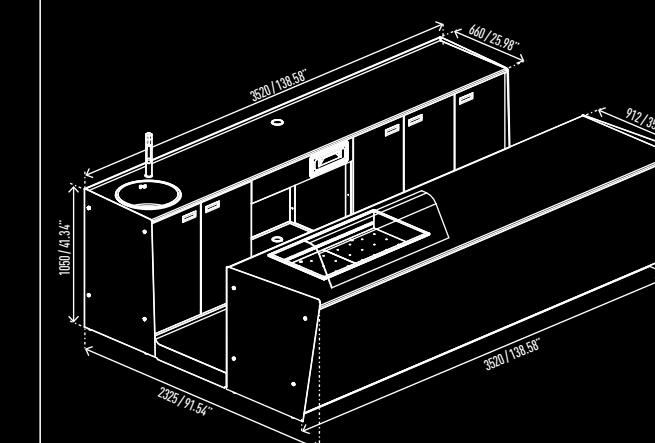

L 3500 SX

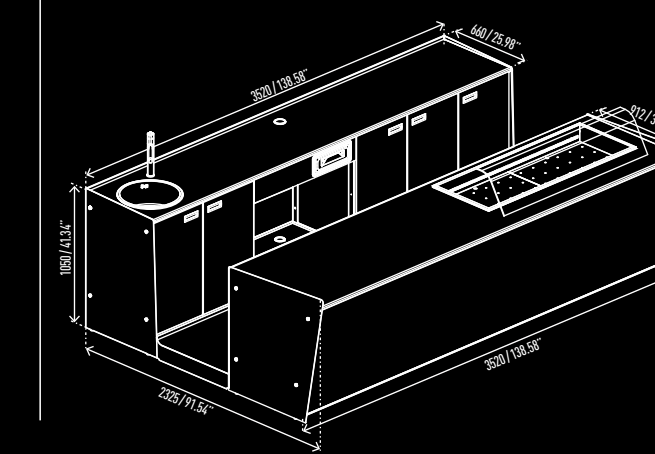

L 4000 DX

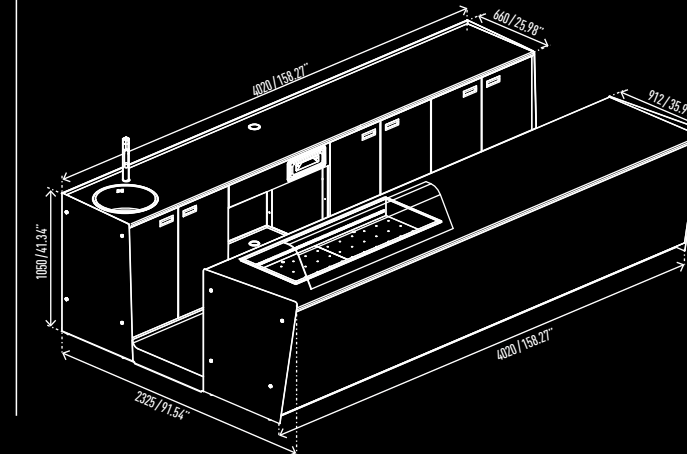



COPERCHI IN PLEXIGLAS PER VASCA REFRIGERATA

Plexiglas covers for the refrigerated tank
Couvercle en plexiglas pour cuve réfrigérée
Plexiglasabdeckung für Kühlwanne
Cubierta de plexiglás para cuba refrigerada



VASCHETTE GASTRONORM CON COPERCHI PER VASCA REFRIGERATA

Gastronorm food trays with lid for the refrigerated tank
Bacs GN avec couvercles pour cuve réfrigérée
GN Wannen mit Deckel für L 1000/L 1400 Kühlwanne
Cubetas GN con tapa para la cuba refrigerada



PIANO CON SERVIZIO CALDO SECCO L 875 E COPERTURA IN PLEXIGLAS CON SCORREVOLI

L 875 display surface with dry heat service and cover with sliding Plexiglas
Plan d'exposition avec service chaleur sèche L 875 et couvercle coulissant en plexiglas
L 875 Ausstellungsfläche mit der Funktion der trockenen Wärme, und Plexiglasabdeckung mit Schiebetüren
Tablero de exposición con servicio calor seco L 875 y cubierta corredera de plexiglás



CASSETTI REFRIGERATI 1/2 X 2 AL POSTO DI 1 SPORTELLO

Tiroirs réfrigérés (1/2 x 2) en remplacement d'une porte
Refrigerated drawers (1/2 x 2) instead of 1 door
2 KühlLaden (1/2 x 2) anstelle einer Tür
2 cajones refrigerados (1/2 x 2) en lugar de 1 puerta



RACCOLTA DIFFERENZIATA CON 2 CONTENITORI DA 35 LITRI CAD.

Waste hopper with 2 storages of 35 liters each
Trappe à ordures avec 2 conteneurs de 35 litres chacun
Abfalltrichter mit 2 Räume (2 Behälter von 35 Litern je)
Tolva residuos con 2 departamentos de 35 litros cada uno

IFI SI RISERVA IL DIRITTO DI APPORTARE MODIFICHE AI PRODOTTI ILLUSTRATI IN QUESTO CATALOGO, IN QUALUNQUE MOMENTO SENZA L'OBBLIGO DI PREAVVISO. LE FINITURE RIPRODOTTE IN QUESTO CATALOGO SONO INDICATIVE PER LE INEVITABILI DIFFERENZE DOVUTE ALLA RIPRODUZIONE TIPOGRAFICA.

IFI reserves the right to make modifications to the products shown in this catalogue at any time without prior notice. The finishings shown in this catalogue are approximate, as a printed reproduction causes inevitable colour differences.

IFI se réserve le droit de modifier les produits de ce catalogue à n'importe quel moment sans obligation de préavis. Les finitions montrées dans ce catalogue sont indicatives à cause des différences en couleur inévitables dues à la reproduction typographique.

IFI hält sich das Recht vor, zu jeder Zeit, die Produkte ohne Vorankündigung abzuändern. Wegen der unvermeidlichen Farbverschiedenheiten, die von der typographischen Reproduktion geschaffen werden, sind die Feinbearbeitungen in diesem Katalog annähernd.

IFI se reserva el derecho de modificar los productos en cualquier momento sin previo aviso. Los acabados reproducidos en este catálogo son exactos debido a las normales variaciones tipográficas.



ISO 9001

ADIMEMBER



IFI S.p.A.
Strada Selva Grossa 28/30
61010 TAVULLIA (PU) - Italy
Tel. +39 0721 20021 - Fax +39 0721 201773
www.ifi.it - info@ifi.it - export@ifi.it

IL CATALOGO È STATO REALIZZATO CON LA COLLABORAZIONE DI:

The catalogue has been produced through the collaboration of:

- CONCEPT
gditullio

- ART DIRECTION
studioieri communication & graphic design
IFI mktg department

- 3-D VISUALIZATION
studioieri communication & graphic design

© COPYRIGHT IFI S.p.A.
TAVULLIA (PU) ITALIA 2014
- TUTTI I DIRITTI RISERVATI
- All rights reserved

01/2014

I PRODOTTI POSSONO ESSERE TUTELATI DA BREVETTO E/O DA DESIGN
Products may be protected by patent and/or design
Les produits peuvent être protégés par brevet et/ou sur leur design
Die Produkte können vom Patent und/oder Design geschützt sein
Los productos pueden ser protegidos por patente y por diseño

www.iltuoprimobar.it



Socialize with IFI



INDUSTRIEIFI